

# MLC 9000 BUS-COMPATIBLE PID CONTROL SYSTEM

## Installation Manual Loop Controller Module

59167-3



All procedures in this Manual should be performed only by personnel competent and authorised to do so. All local and national regulations pertaining to electrical installations must be rigidly observed.

## 1 INSTALLATION - MECHANICAL

### 1.1 SITE PRE-REQUISITES

#### 1.1.1 Enclosure

It is recommended that the MLC 9000 Control System - comprising a Bus Communications Module (BCM) and up to eight Loop Controller Modules (LCMs) - be installed in an enclosure which is sealed against the ingress of dust and moisture. The enclosure must contain sufficient length of 35mm Top-Hat DIN mounting rail to accommodate the system modules (see below) plus an extra 50mm of rail to permit modules to be separated. Module dimensions are shown in Figure 1.

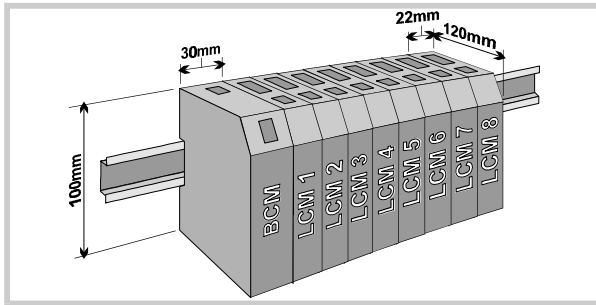

Figure 1 Main Dimensions

**NOTE:** An additional 60mm space is required above and below the Modules to allow ventilation (see below) and to accommodate wiring bend radii to enclosure trunking. During installation, keep the ventilation holes on the Loop Controller Module covered to prevent ingress of dust and moisture.



**WARNING:** The maximum of eight LCMs per system must not be exceeded.

It is recommended that some means of preventing unauthorised access to the enclosure (e.g. lockable doors) is provided.

#### 1.1.2 Ventilation

No forced ventilation or ventilation slots are required in the enclosure but temperatures within the enclosure must be within specification. All modules have ventilation slots in the top and bottom surfaces; these should not be obstructed.

### 1.2 MODULE INSTALLATION

The modules are installed onto the DIN rail in the following order:

1. Bus Communications Module
2. Interconnect Module(s)
3. First Loop Controller Module
4. Second Loop Controller Module etc.

Each LCM must be separated from its Interconnect Module before installation.



**CAUTION: HOT SWAPPING OF LOOP CONTROLLER MODULES.** Although hot swapping of LCMs is possible, caution must be exercised in order to eliminate the risk of receiving an electric shock due to the possibility of up to 240V AC being present at the relay terminals of an LCM. Before removing any connectors from an LCM, please ensure that all hazardous voltages have been isolated from the appropriate connectors.

### 1.2.1 Installing an Interconnect Module

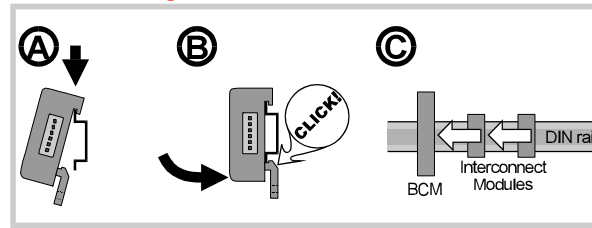

Figure 2 Installing an Interconnect Module

### 1.2.2 Installing an LCM

**NOTE:** Any LCM may be used with any Interconnect Module (i.e. the modules are not matched)

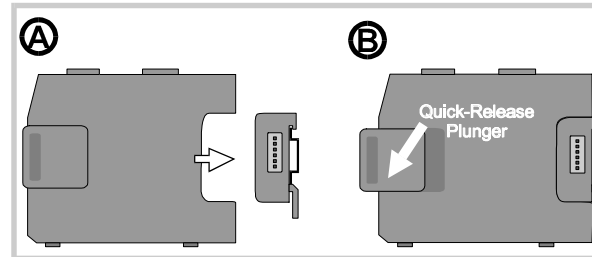

Figure 3 Installing an LCM

## 1.3 REMOVING MODULES FROM THE SYSTEM

### 1.3.1 Removing an LCM

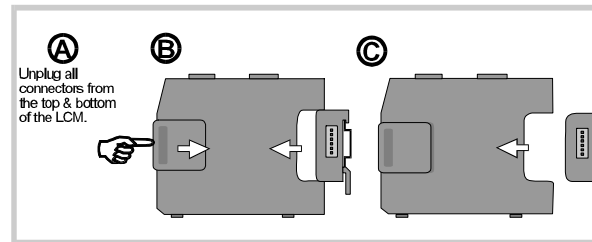

Figure 4 Removing an LCM

### 1.3.2 Removing an Interconnect Module

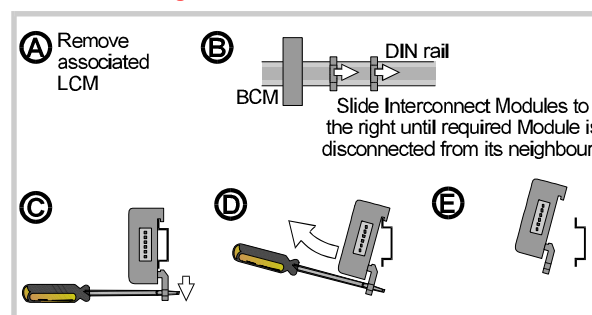

Figure 5 Removing an Interconnect Module

## 2 INSTALLATION - ELECTRICAL

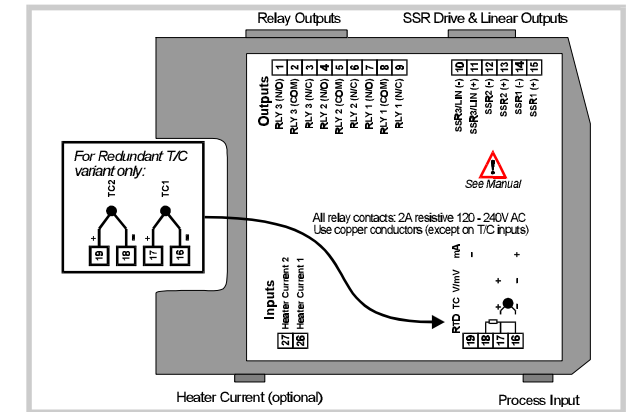

Figure 6 LCM Connectors



**CAUTION:** The system is designed for installation in an enclosure which provides adequate protection against electric shock. Local regulations regarding electrical installation should be rigidly observed. Consideration should be given to prevention of access to the power terminations by unauthorised personnel.

### 2.1 THERMOCOUPLE INPUT

The correct type of extension leadwire/compensation cable must be used for the entire distance between the LCM connector and the thermocouple; correct polarity must be observed throughout. Joints in the cable should be avoided. **NOTE:** Do not run cables adjacent to power-carrying conductors. If the wiring is run in a conduit, use a separate conduit for the thermocouple wiring. If the thermocouple is grounded, this must be done at one point only. If the extension lead is shielded, the shield must be grounded at one point only. **NOTE:** In the Redundant Thermocouple variant, thermocouples should not be grounded or joined together.

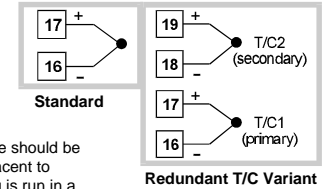

### 2.2 RTD INPUT (3-WIRE)

The extension leads should be of copper and the resistance of the wires connecting the resistance element should not exceed 50Ω per lead (the leads should be of equal length).

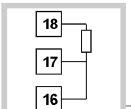

### 2.3 LINEAR INPUT

The linear input ranges are mA, mV and V based.

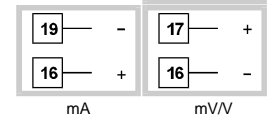

### 2.4 RELAY OUTPUT

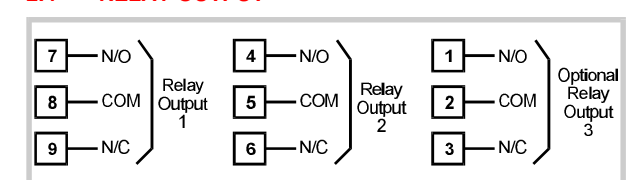

### 2.5 SSR DRIVE AND DC LINEAR OUTPUT

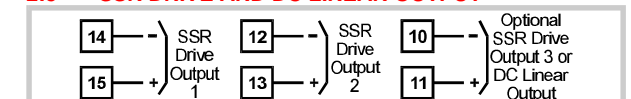

### 3 ON-SITE DIAGNOSTICS



The front panel LED indicator (red/green switchable) provides basic on-site diagnostic information as an aid to fault location:

LED Colour/State	Meaning
OFF	No power
Green flashing (1 second ON, 3 seconds OFF)	Process Variable < Setpoint
Green ON	Process Variable = Setpoint (on control - difference between process variable and setpoint is less than 0.1% of input span)
Green flashing (3 seconds ON, 1 second OFF)	Process Variable > Setpoint
Red flashing (1 second ON, 1 second OFF)	No communication with BCM.
Red fast flashing (0.5 seconds ON, 0.5 seconds OFF)	Auto-addressing is complete but the LCM is inhibited i.e. configuration may be incomplete.
Red ON	An alarm is active.
Orange (green and red simultaneously)	Hardware fault detected.

**NOTE:** An active alarm will over-ride a continuous-green indication; in the case of a flashing green state, indication of an active alarm will appear during the OFF time intervals (i.e. indicator will flash alternate green/red).

### 4 LOOP CONTROLLER MODULE SPECIFICATION

GENERAL	
Function:	Each LCM performs the control function and provides the input and output connections for its own control loop. One universal process input and two outputs are provided as standard. An optional third output and Heater Break detection input are available.
Types available:	(a) Two output, single loop (b) Three output, single loop (c) Three output, single loop with Heater Break detection (d) Three output, single loop with Heater Break detection and redundant thermocouple
Process Input:	Type and scale user-selectable (see below). Sample rate = 10/second. For Redundant Thermocouple variant, unused thermocouple sample rate = 1/second.
Heater Current Input	Generates a Heater Current input value for use by the Heater Break Alarm Function.
Outputs:	Output 1 - Relay or SSR Drive Output 2 - Relay or SSR Drive Output 3 (optional) - Relay, SSR Drive or Linear

PROCESS INPUT Types available (Range Minimum - Range Maximum)			
Thermocouple		RTD	DC Linear
B (100 - 1824°C) B (212 - 3315°F)	N (0.0 - 1399.6°C) N (32.0 - 2551.3°F)	-199.9 - 800.3°C -327.3 - 1472.5°F	0 - 20mA 4 - 20mA
J (-200.1 - 1200.3°C) J (-328.2 - 2192.5°F)	R (0 - 1759°C) R (32 - 3198°F)		0 - 50mV 10 - 50mV
K (-240.1 - 1372.9°C) K (-400.2 - 2503.2°F)	S (0 - 1759°C) S (32 - 3198°F)		0 - 5V 1 - 5V
L (-0.1 - 761.4°C) L (31.8 - 1402.5°F)	T (-240.0 - 400.5°C) T (-400.0 - 752.9°F)		0 - 10V 2 - 10V

PROCESS INPUT Over-range Detection, Under-range Detection and Sensor Break detection	
Under-range Detection	An under-range indication is given when the input value is lower than Range Minimum. The input value is valid for reading and control for up to 5% of input span under-range. The accuracy is reduced when the input is under-range. Sensor break is not detected until the input is at least 10% under-range.

PROCESS INPUT Over-range Detection, Under-range Detection and Sensor Break detection	
Over-range Detection	An over-range indication is given when the input value exceeds Range Maximum. The input value is valid for reading and control for up to 5% of input span over-range. The accuracy is reduced when the input is over-range. Sensor break is not detected until the input is at least 10% over-range.
Sensor Break Detection	Primary thermocouple input: wire break detected within two seconds. Secondary thermocouple input (redundant thermocouple variant only): wire break detected typically within three seconds. Control outputs set to OFF (0% power); All alarms become active (with the exception of heater break - if present). For DC Linear inputs, applicable to 4 - 20mA, 10 - 50mV, 1 - 5V and 2 - 10V ranges only. NOTE: For the Redundant Thermocouple variant, a detected break on the primary thermocouple circuit will cause an automatic switch to the secondary thermocouple. If the primary thermocouple break is corrected, this causes an automatic return to the primary thermocouple. Whichever thermocouple is in use, the used thermocouple sample rate = 10/second and the unused thermocouple sample rate = 1/second. A break on both thermocouple circuits will have the same effect as a sensor break on the standard LCM. See also Under-range Detection and Over-range Detection above.

THERMOCOUPLE INPUTS	
Types/Ranges	See above
Measurement Accuracy	Better than ±0.1% of range span ±1 LSD. NOTE: Reduced performance with Type "B" Thermocouple between 100 - 600°C (212 - 1112°F).
Linearisation Accuracy	Better than ±0.2°C any point, any 0.1°C resolution range (±0.05°C typical). Better than ±0.5°C any point, any 1°C resolution range.
Cold Junction Compensation	Primary Input: Better than ±1°C over operating temperature range. Secondary Input (Redundant Thermocouple variant only): Better than ±2°C over operating temperature range.
Sensor Resistance Influence	<10Ω: as measurement accuracy 100Ω: <0.1% of range span error 1000Ω: <0.5% of range span error

RTD INPUTS (not on Redundant Thermocouple variant)	
Type and Connection:	Three-wire (Pt100)
Measurement Accuracy	±0.1% of range span ±1 LSD.
Linearisation Accuracy	Better than ±0.2°C any point, any 0.1°C resolution range (±0.05°C typical). Better than ±0.5°C any point, any 1°C resolution range.
Temperature Stability	0.01% of range span/°C change in ambient temperature.
Lead Compensation:	Automatic to 50Ω maximum lead resistance, giving less than 0.5% of range span additional error.
RTD Sensor Current:	150 microamps (approximately).

DC LINEAR INPUTS (not on Redundant Thermocouple variant)	
Measurement Accuracy	Better than ±0.1% of range span ±1 LSD.
Temperature Stability	0.01% of range span/°C change in ambient temperature.
Source Resistance	≤1000Ω for voltage inputs >1000Ω for current inputs
Max. Resolution	-32000 to 32000. Equivalent to a 16-bit ADC.

HEATER CURRENT INPUT	
Input Sampling Method:	Delta-sigma at 1kHz
Input Resolution:	8 bits over 250 msec rolling window
Accuracy:	Better than ±2%.
Isolation:	Via external current transformer
Internal Burden:	15 ohm
Source Selection:	SSR linear output 3 or Heater Current input.

HEATER CURRENT INPUT	
Input Span:	0 - 50mA rms. (assuming sinusoidal input current waveform)
Range Maximum:	Adjustable 0.1A to 100A
Range Minimum:	Fixed 0A

RELAY OUTPUTS (Output 1, 2 or 3)	
Contact Type:	Single pole double throw (SPDT).
Rating:	2A resistive @ 120/240V AC
Lifetime:	>500,000 operations at rated voltage/current.

SSR DRIVE OUTPUTS (Output 1, 2 or 3)	
Drive Capability:	12V DC nominal (10V DC minimum) into 500Ω minimum.
Isolation:	Isolated from process input and relay outputs. Not isolated from each other or linear outputs. Not isolated from other similar outputs in the same system.

LINEAR OUTPUT (Output 3 only)	
Resolution:	Eight bits in 250msecs. (10 bits in 1 second typical).
Accuracy:	±0.25% (mA into 250Ω load, V into 2kΩ load). Degrading linearly to ±0.5% for increasing burden to maximum drive capability.
Update Rate:	10samples/second.
Drive Capability:	0 - 20mA: 500Ω maximum      4 - 20mA: 500Ω maximum 0 - 5V: 500Ω minimum            0 - 10V: 500Ω minimum
Isolation:	Isolated from process input and relay outputs. Not isolated from SSR Drive outputs or other similar outputs in the same system.

ALARM CONTROL	
Maximum No. of Alarms:	Two "soft" alarms plus Loop Alarm.
Maximum No. of Alarm Outputs Available:	Any output can be used for any alarm indication.
Alarm Types Available:	Process High Alarm Process Low Alarm Band Alarm Deviation Alarm
Combinatorial Alarms:	Logical OR of alarms to an individual hardware output is available.

OPERATING CONDITIONS	
Ambient Temperature:	0°C to 55°C (operating); -20°C to 80°C (storage)
Relative Humidity:	30% - 90% non-condensing (operation and storage).
Supply Voltage:	Powered by BCM within its operating conditions.

APPROVALS	
Product-specific EMC:	EN61326-1:1997.
Generic EMC Susceptibility:	EN61000-6-2:1999 (supercedes EN50082-2:1997). <b>NOTE:</b> For line-conducted AM signals in the frequency range 400kHz to 1.65MHz, communications with the RS485 MODBUS and RS232 ports may be disrupted but will self-recover when the interfering signals are removed.
Generic EMI Emissions:	EN50081-2:1994.
Safety:	Complies with EN61010-1:1993 and UL3121-1:1998.

PHYSICAL	
Dimensions:	Height - 100mm; Width - 22mm; Depth - 120mm
Mounting:	DIN rail mounting via Interconnect Module.
Connector Types:	Process Input - open end header, 5.08mm Combicon type. Relay Outputs: open end header, 5.08mm Combicon type SSR Drive/DC Linear Outputs: open end header, 5.08mm Combicon type. Heater Current Input: open end header, 5.08mm Combicon type.
Weight:	0.15kg.