

MLC 9000 BUS-COMPATIBLE PID CONTROL SYSTEM Installation Manual Bus Communications Module (DeviceNet) 59205-1 (January 2001) (H1175)

! All procedures in this Manual should be performed only by personnel competent and authorised to do so. All local and national regulations pertaining to electrical installations must be rigidly observed.

1 INSTALLATION - MECHANICAL

1.1 SITE PRE-REQUISITES

1.1.1 Enclosure

It is recommended that the MLC 9000 System - comprising a Bus Communications Module (BCM) and up to eight Loop Controller Modules (LCMs) - be installed in an enclosure which is sealed against the ingress of dust and moisture. The enclosure must contain sufficient length of 35mm Top-Hat DIN mounting rail to accommodate the system modules (see below) plus an extra 50mm of rail to permit modules to be separated. Module dimensions are shown in Figure 1.

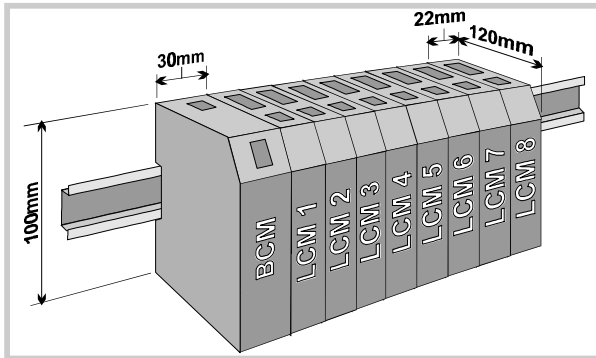

Figure 1 Main Dimensions

NOTE: An additional 60mm space is required above and below the Modules to allow ventilation (see below) and to accommodate wiring bend radii to enclosure trunking. During installation, keep the ventilation holes on the Loop Controller Module covered to prevent ingress of dust and moisture.

! **WARNING:** The maximum of eight LCMs per BCM must not be exceeded.

It is recommended that some means of preventing unauthorised access within the enclosure (e.g. lockable doors) is provided.

1.1.2 Ventilation

No forced ventilation or ventilation slots are required in the enclosure but temperatures within the enclosure must be within specification. All modules have ventilation slots in the top and bottom surfaces; these should not be obstructed.

1.2 INSTALLING THE BCM

The modules are installed onto the DIN rail in the following order:

1. Bus Communications Module
 2. Interconnect Module(s)
 3. First Loop Controller Module
 4. Second Loop Controller Module
 5. Third Loop Controller Module
- etc.

See Figure 2

! **CAUTION:** Ensure that power has been removed from all equipment currently in the enclosure before installing the BCM.

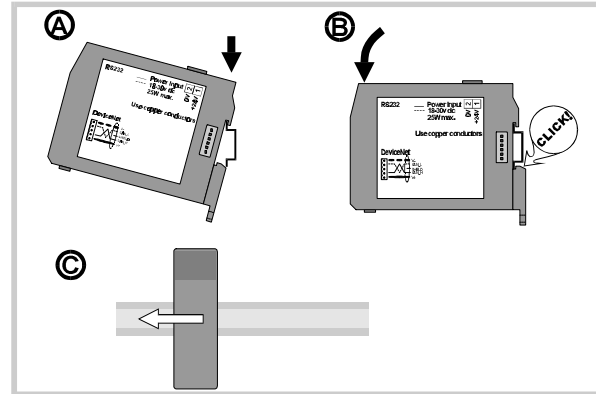

Figure 2 Installing the BCM

1.3 REMOVING THE BCM

! **CAUTION:** Ensure that power has been removed from all equipment currently in the enclosure before removing the BCM.

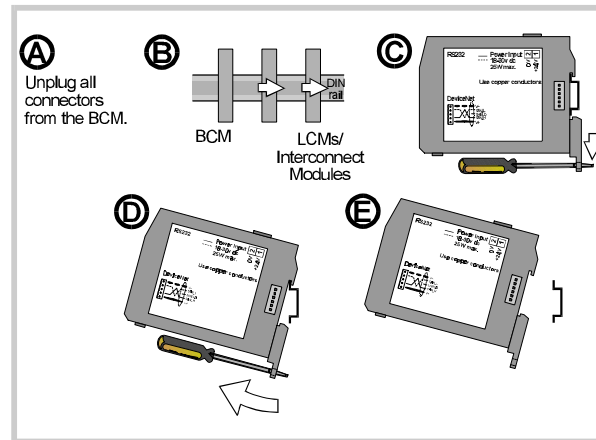

Figure 3 Removing a Bus Communications Module

2 INSTALLATION - ELECTRICAL

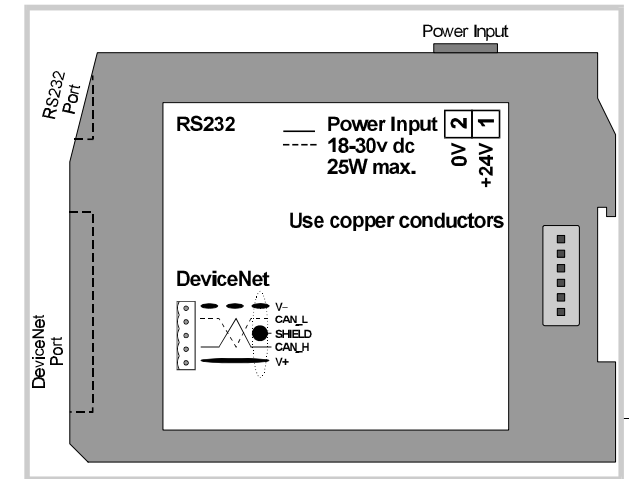

Figure 4 BCM Connectors

2.1 POWER INPUT

The system requires a power input of 18 - 30V DC and has a maximum power consumption of 25W. It is recommended that the power supply is connected via a two-pole isolating switch (preferably situated near the System) and a 2A slow-blow fuse (see Figure 5).

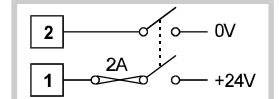

Figure 5 Recommended Mode of Power Connection

! **CAUTION:** The system is designed for installation in an enclosure which provides adequate protection against electric shock. Local regulations regarding electrical installation should be rigidly observed. Consideration should be given to prevention of access to the power terminations by unauthorised personnel.

2.2 RS232 PORT

NOTE: A proprietary protocol is employed on this port. This connects the BCM to a local PC (for local configuration and basic operator functions) or HMI (e.g. a remote front panel/operator interface). Pin connections are shown on the right.

Pin No.	Signal/Function
1	Receive Data
2	Transmit Data
3	No connection
4	Signal Ground

2.3 DEVICENET PORT

This connects the BCM to a DeviceNet network. Pin connections are shown on the right. The SHIELD connection is provided for termination of screened cable, if required.

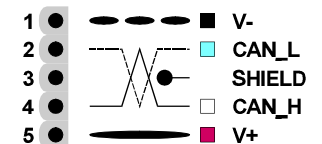

3 INSTALLING THE CONFIGURATOR ON YOUR PC



NOTE: The MLC 9000 Configurator is an optional item.

3.1 INITIAL INSTALLATION

1. Insert the Configurator CD-ROM into the appropriate drive on your PC. Note: The Setup program should start automatically; if it does not, navigate to the appropriate drive using Windows Explorer and run the Setup icon.
2. The Setup program will run the Setup Wizard, which will guide you through the installation procedure. You will be prompted to enter your name and company name.
3. You will be prompted to define a folder into which you want the Configurator installed. You may use the default folder or specify one of your own choice.
4. When prompted for the installation type, select the type most appropriate to your needs. If in doubt, select the **Typical** option. The **Custom** option allows you to specify the components to be installed.
5. Upon completion of the installation, you will be prompted to run the Configurator.

3.2 ADDING SUPPORT FOR NEW SYSTEM MODULES

Additional support software for new modules may be added to the existing Configurator on your PC. This will enable you to use the updated Configurator to configure the new modules. To add new support software:

1. Insert the diskette containing the new support software into the appropriate drive on your PC.
2. Run the existing Configurator.
3. From the **Contents** page, select the **Manage Device Drivers** option.
4. Click the **Add** button. The Add New Driver Wizard will guide you through the installation process.
5. When you are prompted for the location of the new device files, select the drive containing the new support software diskette.
6. Follow the remaining steps in the Add New Driver Wizard procedure to complete the installation.

Your Configurator is now updated to include the new module(s).

4 ON-SITE DIAGNOSTICS



RS232 Connector

RS232 Port LED

DeviceNet Port LED

DeviceNet Connector

The front panel LED indicators provide basic on-site diagnostic information as an aid to fault location:

RS232 Port LED State*	Meaning	DeviceNet Port LED State	Meaning
OFF	No power	OFF	Not on-line; Duplicate MAC ID Test not completed.
Green, flashing (1 second ON, 1 second OFF)	Communication established with PC (i.e. PC is responding to polls)	Green, continuous	Normal operation. On-line with connections in the established state; has been allocated a Master.
Red, continuous	Power ON and Bus Ready alarm present	Green, flashing	Normal condition, on-line with no connections in the established state; has not been allocated a Master.
Green, continuous	Power ON and OK	Red, continuous	Failed communication; bus fault or power-up self-test failed.
Red/green, flashing (1 second red, 1 second green)	Communications established with PC and Bus Ready alarm		

* On power-up, the RS232 Port LED will initially be orange for one second.

5 MODULE SPECIFICATION

GENERAL	
RS232 Port:	This is a local port for connection to an RS232 port on a PC for local operator configuration and operator displays. It has EIA-232-E (RS232)-compatible inputs and outputs for Tx/D and Rx/D and provides facilities via the Application Software to allow an installer to configure or an operator to view the operation of Loop Controller Modules connected to the Bus Communications Module.
DeviceNet Port	This port is for connection to a DeviceNet network. Data rate and MAC ID are configurable via the RS232 port. The data rate is selectable from (in kbps) 125, 250 or 500. It is factory-set to 125kbps. The MAC ID can be set in the range 0 - 63 (default = 63).
Input Power	25W maximum

ENVIRONMENTAL	
Operating Conditions	Ambient Temperature: 0°C to 55°C Relative Humidity: 30% to 90% non-condensing Supply Voltage: 18 to 30V DC (including ripple)
Storage Conditions	Ambient Temperature: -20°C to 80°C Relative Humidity: 30% to 90% non-condensing

APPROVALS	
Product-specific EMC	EN61326:1998.
Generic EMC Susceptibility	EN61000-6-2:1999 (supersedes EN50082-2:1997). NOTE: For line-conducted AM signals in the frequency ranges 16-20MHz and 5.5-7.5MHz, the DeviceNet port can suffer intermittent loss of function which is self-recoverable. In the frequency range 1-6MHz, communications with the RS232 port may be disrupted but will self-recover when the interfering signals are removed.
Generic EMC Emissions	EN50081-2:1994.
Safety	Complies with EN61010-1:1995 and UL 3121-1:1998.

PHYSICAL	
Dimensions	Height - 100mm; Width - 30mm; Depth - 120mm
Mounting	Directly mounted on the DIN rail
Connectors	Power input: 2-way 5.08mm Combicon type RS232 port: 6-way RJII Type DeviceNet port: 5-way 5.08mm Combicon type
Weight:	0.21kg